



WHERE
PRECISION
DRIVES
PRODUCTION



PVA3000

AUTOMATED DISPENSING SOLUTIONS THAT WORK...



CONSISTENTLY.

The PVA3000 is a robust motion platform that is configurable for virtually any automated adhesive dispensing application. Utilizing PVA's wide selection of applicators, the PVA3000 platform is ideal for single or dual-component gasketing, potting, or dot placement processes.

ROBOTIC PLATFORM

A highly accurate (X-Y-Z accuracy rated at +/- 0.025 mm (0.001 in)) brushless DC servo motor drive system guides precision-grade ball screw slides across a large 500 mm x 500 mm x 100 mm (19.68 in x 19.68 in x 3.94 in) work area. The PVA3000 provides continuous, coordinated, motion across all three-axes simultaneously without steps, allowing the user to create seamless 3D line motion. Closed-loop optical encoder feedback on all axes provides continuous data on the robot's position assuring accuracy across the entire work area. The PVA3000 is constructed of a flexible extruded aluminum frame that permits customization in shape and size for oversized assemblies.



PROCESS FLEXIBILITY

PVA provides customized turnkey solutions that best fit your application and budget. Coatings, paints, RTV, epoxies, pastes, and more can be applied in dot, bead, and potting solutions. PVA offers the variety you need to perfectly match your requirements, including:

- ▲ Conveyorized, shuttled, or manually loaded processes.
- ▲ Custom process integration and part nest design.
- ▲ Fluid delivery systems ranging from syringes to drum pumps to handle any material package size.



- ▲ Positive displacement, auger, diaphragm, pinch tube, or time and pressure valve mount options.
- ▲ Process control features including flow monitoring, needle calibration, height sensing, and more.

The PVA3000 can be tooled to satisfy multiple dispensing applications or chemistries on just one robot. Custom head configurations can also be designed to process multiple parts simultaneously and increase throughput.

PROCESS KNOWLEDGE

The PVA3000 is fully supported by PathMaster® software. PathMaster® is PVA's proprietary Windows®-based system control platform. It permits creation of arcs, circles, lines, and dots in two, three, or four-dimensional planes with a simple point and click method. A remote trackball teach pendant permits you to toggle the robot position in all axes to teach coordinates. PathMaster® also contains a FastPath® offline programming package that allows motion to be generated at your desktop via CAD download and digital image import capability.



The PVA3000 can store up to 30 programs of motion in the robot's non-volatile memory for immediate recall from the front panel screen. Increased memory capacity can be obtained by connecting a computer system to the PVA3000. PathMaster is a standard feature on all PVA3000 robots and is available in Windows® 95, 98, 2000, Me, and NT formats.

GLOBAL SERVICE & SUPPORT



PVA provides 24-hour global support for all products and services. Circuits Assembly honored PVA with their prestigious Service Excellence Award for three consecutive years citing unparalleled responsiveness and customer satisfaction in the dispensing industry. PVA has international breadth

with satellite service capabilities around the globe to support our headquarters in New York.

For an online tour of the PVA3000, visit www.pva.net/PVA3000.html



PathMaster® is a registered trademark of Precision Valve & Automation, Inc.
Windows® is a registered trademark of Microsoft Corporation.

PVA3000

SPECIFICATIONS

MOTION PLATFORM

X-Y-Z Axes

Brushless DC servo motor driven precision ball screw with closed-loop, high-resolution encoder feedback

Encoder Resolution

0.005 mm
(0.0002 in)

X-Y-Z Accuracy

+/-0.025 mm
(0.001 in)

Dispense Area

500 mm x 500 mm
(19.68 in x 19.68 in)

Z-Axis Travel

100 mm
(3.94 in)

Travel Speed

0 to 700 mm/sec
(0 to 27.6 in/sec)

Payload Capacity

25 pounds
(11.4 kg)

OPTIONAL CONVEYOR

Transport

Edge carrying belt or pin chain conveyor

Compatibility

SMEMA

Edge Clearance

4.8 mm standard
(0.189 in standard)

Drive

Variable speed and direction

Height

Adjustable between 940 mm and 965 mm
(Adjustable between 37 in and 38 in)

SOFTWARE

User Environment

PathMaster™ for Windows®

Operating System

Windows® 95, 98, 2000, Me, and NT formats

FACILITY REQUIREMENTS

Power Requirements

120V, 220V, +/-10%, 50-60 Hz

Air Supply Requirements

80 PSI dry, unlubricated air

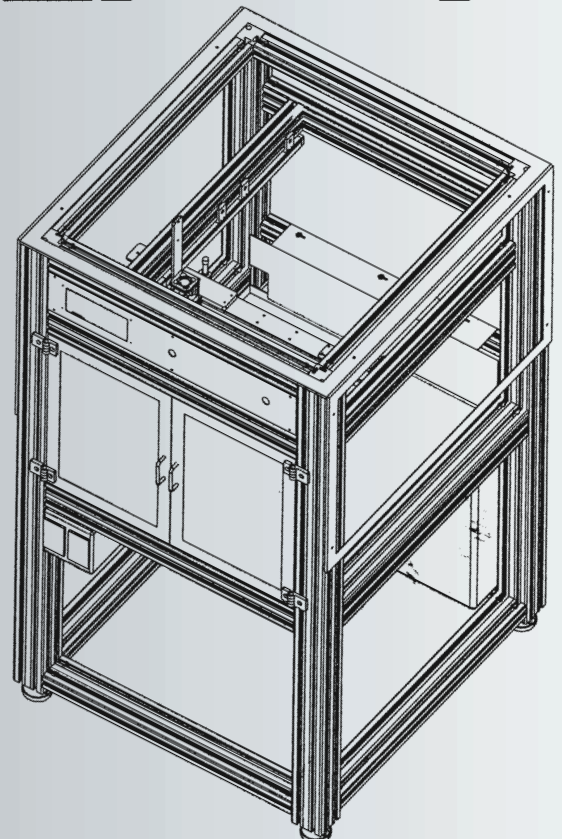
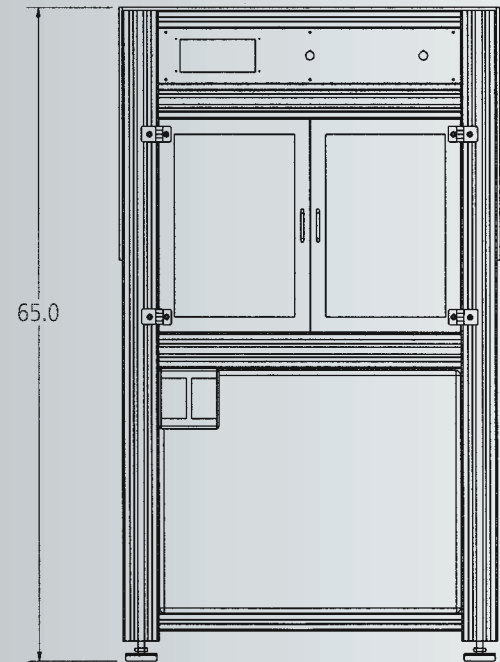
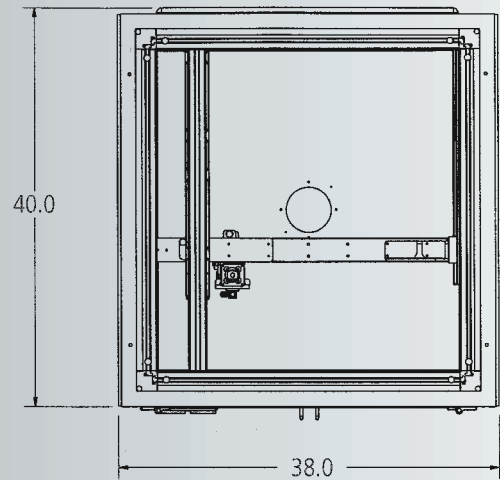

15 Solar Drive
Halfmoon NY 12065
tel 518 371 2684
fx 518 371 2688
info@pva.net
web www.pva.net